

D. D. MILLER.  
 FOLDING CRATE.  
 APPLICATION FILED AUG. 23, 1912.

1,096,553.

Patented May 12, 1914.

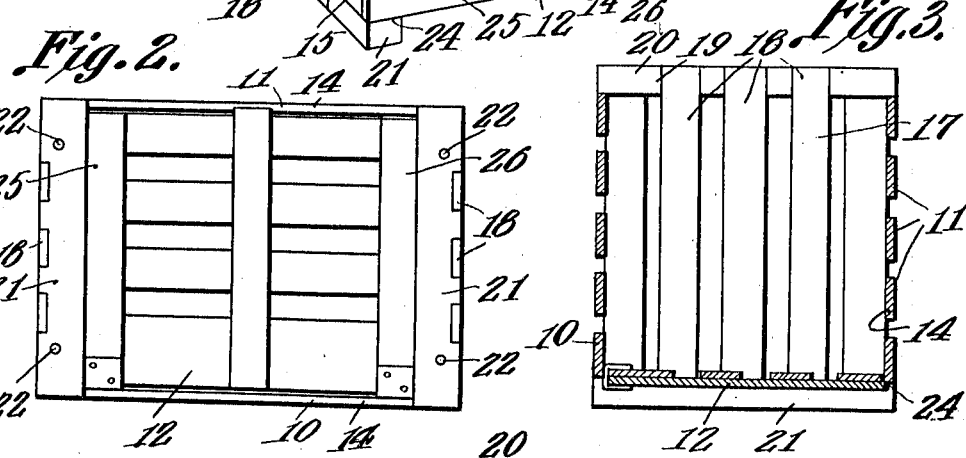
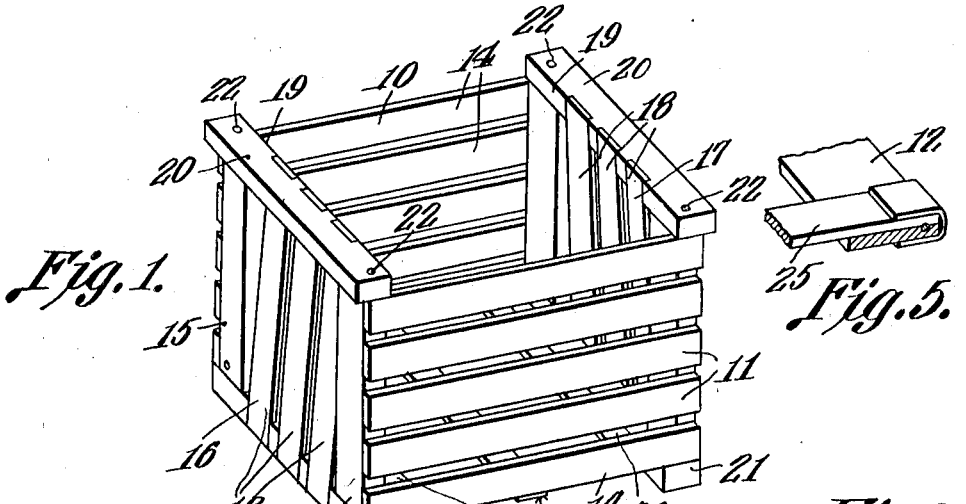

Witnesses  
*J. J. [Signature]*  
*L. S. [Signature]*

D. D. Miller,  
 Inventor  
 by *C. A. Snow & Co.*  
 Attorneys

# UNITED STATES PATENT OFFICE.

DANIEL D. MILLER, OF BURTON, OHIO.

## FOLDING CRATE.

1,096,553.

Specification of Letters Patent.

Patented May 12, 1914.

Application filed August 23, 1912. Serial No. 716,755.

*To all whom it may concern:*

Be it known that I, DANIEL D. MILLER, a citizen of the United States, residing at Burton, in the county of Geauga and State of Ohio, have invented a new and useful Folding Crate, of which the following is a specification.

This invention relates to an improvement in folding crates.

The primary object of the present invention is to provide a crate which may be folded to occupy a comparatively small space, the bottom member of which when the same is extended preventing the side and end walls from folding.

Another object is to provide a crate, the inner surfaces thereof being free from obstructions which would interfere with the proper removing of the articles from the crate when the latter is inverted.

A further object is to provide a folding crate with a bottom hingedly secured thereto and with the side slats extending from the outer surface of the base beams to the inner surface of the top beams whereby a broad flat support will be had for the hinged bottom of the crate. Furthermore the central slat of the bottom is prolonged so as to coact with the lowermost slat of the side which latter acts in the capacity of a latch for the former and holds the bottom rigidly in place against accidental folding when the crate is inverted.

With the foregoing and other objects in view which will appear as the description proceeds, the invention resides in the combination and arrangement of parts and in the details of construction hereinafter described and claimed, it being understood that changes in the precise embodiment of the invention herein disclosed can be made within the scope of what is claimed without departing from the spirit of the invention.

In the drawings Figure 1 is a perspective view. Fig. 2 is a bottom plan view. Fig. 3 is a transverse sectional view. Fig. 4 is a view showing the crate folded. Fig. 5 is a fragmental view in perspective of a portion of the crate bottom and illustrating the metallic strap which extends around a portion thereof so as to brace the same at its point of pivotal connection.

In the drawings 10 designates one of the side walls which is formed of a plurality of slats 14, the bottom 12 being pivotally connected to said side wall, the longitudinal

slats 14 of the side walls 10 and 11, being secured at either end to posts 15, which form its pivotal connection with the end walls 16 and 17. The central slat of the bottom member is of a length in excess of the other slats of said member, the terminal of said slat contacting with the side wall of the crate to securely lock the bottom in position. The natural resiliency of the slat of the side wall provides that the same will act in the capacity of a latch being swung slightly forward as the bottom is swung downward into its normal position and snapping back over the central slat to hold the said bottom in place. When it is desired to move the bottom upwardly the side wall slat is swung forwardly, releasing the bottom slat, the desired result thereby being obtained. The end wall consists of the vertically disposed slats 18 which are connected at the open ends of the crate to the inner face 19 of a beam 20 and at the base of the crate to the outer face of the beam 21. The particular advantage accruing from this construction lies in the fact that the walls so formed are much stronger than if the slats were disposed in the usual manner, the slats being adapted to withstand pressure from within or without the crate in a more successful manner. Furthermore the attaching of the slats to the inner face of the beam 19 provides for hand holds or gripping means as will be apparent from a reference to Fig. 1. The beams 20 and 21 receive pins 22 which extend within the ends of the vertically disposed end posts of the side walls, the end and side walls being thus properly connected to allow the same to be folded, the bottom member being folded upon the side wall 10. The crate when folded in this manner occupies but small space when not in use.

Particular attention is called to the formation of the side walls and the manner in which the edges 24 of the lower beams 21 co-act with the bottom member to present a smooth interior which will prevent injury to the fruit or vegetables contained in the crate. The providing of the vertically disposed slats 18 upon the inner face of the beams 20 allows the crate to be inverted and the articles ejected therefrom without bruising the said articles due to the fact that there are no ledges or obstructions upon the inner surface of the crate. Attention is also directed to the fact that when the bottom is in position, the slats 25 and 26 of the same

will contact with the vertical posts of the side wall forming a substantial bottom structure.

The many advantages of a crate of this character will be clearly apparent as it will be noted that the construction is such as may be easily and economically manufactured and that the various parts may be readily assembled.

10 What is claimed is:

1. A folding crate comprising side walls formed of longitudinal slats and vertical posts, a bottom pivotally supported by the posts of one of the side walls, end walls consisting of vertical slats and longitudinal beams, said slats of the end walls secured at their lower ends to the outer faces of said beams and to the inner faces of the upper beams at their upper ends, the end walls thereby adapted to resist internal and external pressure thereon equally well, said upper longitudinal beams providing gripping means for the handling of the crate, and the end walls providing a crate with smooth interior surfaces free from obstructions which would tend to prevent the ejecting of material therefrom upon an inversion of the crate.

2. A folding crate comprising side walls formed of longitudinal slats, and vertical posts, a bottom pivotally supported by the posts of one of the side walls, end walls including vertical slats and longitudinal beams rigidly secured together, said slats being secured at their lower ends to the outer face of the beams and to the inner face of the upper beams at their upper ends, the said bottom adapted to rest upon the ledge formed by the securing of the said slats to the outer face of the lower beams, the central slat of the bottom extended and coacting with one of the slats of the side walls adapted to securely lock the said bottom in its normal position, said bottom preventing the collapsing of said crate, the disposition of said vertical slats allowing for the free ejection of material from the crate by an inversion thereof.

In testimony that I claim the foregoing as my own, I have hereto affixed my signature in the presence of two witnesses.

DANIEL D. MILLER.

Witnesses:

E. E. RUSSELL,  
C. H. VARNEY.